

## TR30B+C SPD TUV approved

SPD type 1+2–surge arrester, MOV  
Pluggable module, visual fault signalling

- Varistor surge arrester
- Installation to main distribution or sub–distribution boards
- For protection of installations and equipments against impact of induced overvoltage during a lightning strike or switching overvoltages.
- Optional remote fault signalling(s)

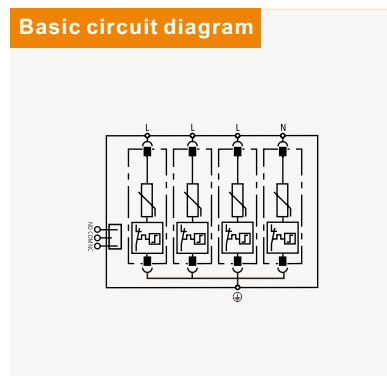
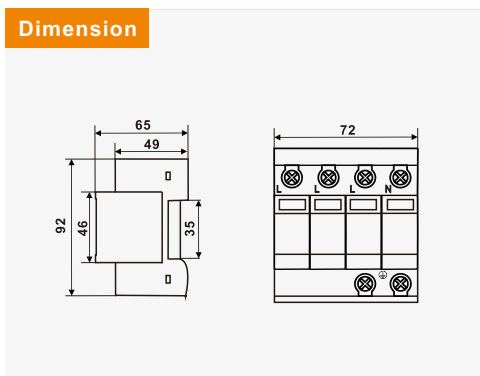

Parameter/Type		TRS30B+C
Nominal voltage	$U_n$	230V AC
Maximum operating voltage	$U_c$	275V AC
Lightning impulse current(10/350 $\mu$ s)	$I_{imp}$	4,5kA
Nominal discharge current (8/20 $\mu$ s)	$I_n$	30kA
Maximum discharge current (8/20 $\mu$ s)	$I_{max}$	60kA
Voltage protection level	$U_p$	$\leq 1,5kV$
Response time	$t_a$	< 25ns
Cross–section of connected conductors solid(min/max)		16mm <sup>2</sup> /35mm <sup>2</sup>
Cross–section of connected conductors stranded(min/max)		16mm <sup>2</sup> /35mm <sup>2</sup>
Fault indication		red indication field
Remote indication		potential–free change–over contact
remote indication contacts		250V/0,5A AC,250V/0,1A DC
Cross–section of remote indication conductors		1,5mm <sup>2</sup>
Degree of protection		IP20
Range of operating temperatures (min/ max)		–40°C~+85°C
Humidity range		5%~95%
Mounting		DIN rail 35 mm
According to standard		EN 61643–11:2012,IEC 61643–11:2011/T1+T2
Remarks		Other $U_c$ can be customized.(420VAC,385VAC,320VAC,etc.)